

2 BURNER PORTABLE GAS BBQ

Model BG2102D2

- Folding stand with wheels
- Porcelain-enamelled hood and grill
- 22 Mj/H output with piezo ignition
- Hose and LCC27 gas regulator included

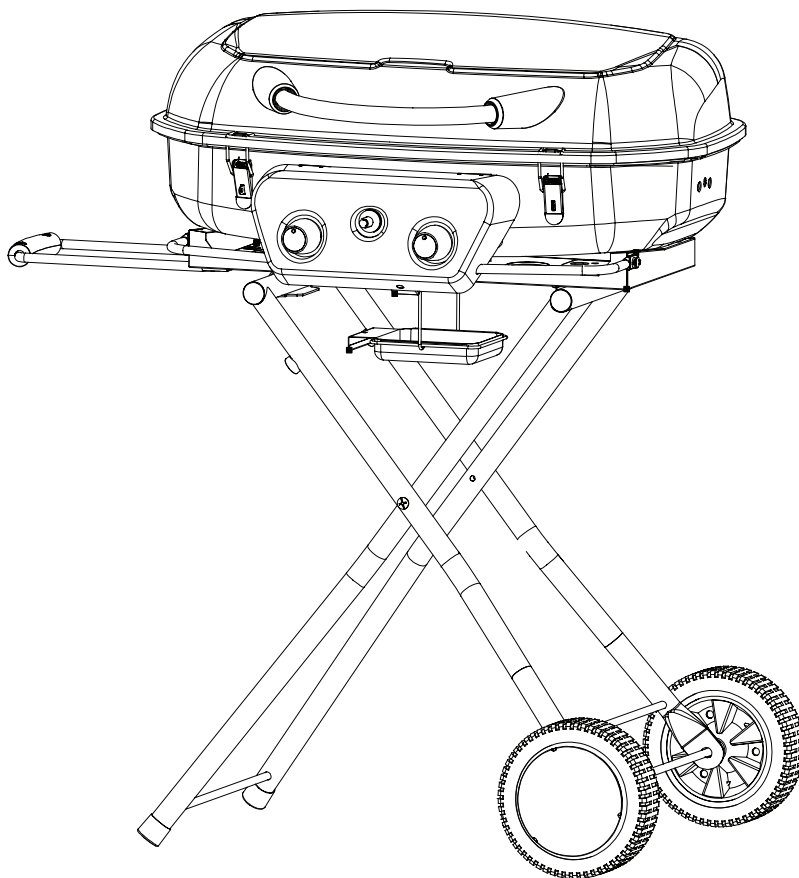

Important: Please save these instructions for future reference
THIS BARBEQUE IS INTENDED FOR OUTDOOR USE ONLY

IMPORTANT SAFETY AND USE INFORMATION

Important. Read these instructions for use carefully.

Familiarise yourself with the appliance before connecting it to its gas container.

Keep these instructions for future reference.

1. **WARNING!**⚠

**FOR OUTDOOR USE ONLY!
DO NOT USE INDOORS. ONLY USE
IN WELL-VENTILATED AREAS.**

- Please read and follow these installation, maintenance and operation instructions carefully before assembling, installing, servicing or using this appliance.
- The barbeque is for permitted outdoor residential use only and must be placed on a stable, firm, level and non-combustible outdoor surface for use.
- Improper installation, use, alteration, service or maintenance, or failure to follow these instructions could result in fire or explosion and lead to serious injury, death and/or significant damage to property.
- Do not start the barbeque if there is any doubt over the correct assembly, ignition, gas control or cooking use of the barbeque.
- Follow all warnings and instructions when using this barbeque. These instructions contain important information necessary for its proper assembly and safe use and should be retained for future reference.
- For use with propane cylinder gas only.
- The barbeque must have a minimum side clearance from any combustible material of at least 250mm. Additionally there must be a clearance of at least 1500mm above the cooking surface of the barbeque, and 350mm clearance at the back.
- Do not store or use gasoline or other flammable liquids, vapours or materials in or near this appliance.
- Do not place any article on or against this appliance.
- Do not modify this appliance.
- Do not spray aerosols in the vicinity of this appliance while it is in operation.
- A lit barbeque should be attended at all times. Avoid using in windy conditions.
- Gas cylinder **MUST** be stored vertically and never where temperatures can exceed 50 °C.
- Do not use this appliance if it is leaking, damaged or does not operate properly.
- Do not store any gas cylinder not connected for use in the vicinity of this appliance.
- Avoid dousing the barbeque with water.
- Turn off the gas cylinder supply valve when the barbeque is not in use.
- Always allow the barbeque to cool completely before cleaning or covering.
- For safety reasons it is advisable to keep a fire extinguisher and blanket close to hand when using this barbeque.
- Unsupervised children, and elderly or infirm people should not be allowed close to the barbeque during pre-heat, cooking, burn off or cooling down of the unit.
- Please remove/dispose of all transit protection (polythene packing and plastic bags) carefully and keep out of the reach of children and pets.
- **CARBON MONOXIDE HAZARD - USING THIS APPLIANCE IN AN ENCLOSED OR HABITABLE SPACE MAY CAUSE DEATH. DO NOT USE IN CARAVANS, TENTS, MARINE CRAFT, CARS, MOBILE HOMES OR SIMILAR LOCATIONS. NEVER USE THIS APPLIANCE AS A HEATER.**
- **WARNING!**⚠ Accessible parts will become very hot. Use gloves when using and allow to cool before touching.
- **WARNING!**⚠ Keep young children and pets away from barbeque at all times.
- **WARNING!**⚠ Any service shall be carried out by authorised persons only.
- Do not install in, or connect to the consumer piping or gas system of a boat or caravan.
- NEVER leave a lit barbeque unattended.
- NEVER block side or back vents or move barbeque when it is in use.
- NEVER use lighter fluid, charcoal, gasoline or other flammable fuels in this barbeque.
- Clean and inspect barbeque, cylinder and hose before each use, and on a regular basis. See BARBEQUE CLEANING AND CARE (page 18).
- Inspect gas hose before each use and replace if it shows signs of wear, abrasion or cuts. Do not attempt to modify any damaged hose assembly. Call customer service to request a replacement hose assembly.

IMPORTANT SAFETY AND USE INFORMATION

Important. Read these instructions for use carefully.

Familiarise yourself with the appliance before connecting it to its gas container.

Keep these instructions for future reference.

2. GAS CYLINDER, TYPE AND REGULATOR

- This appliance shall only be used with ULPG gas from cylinders complying with AS2469 and AS2030. It may be hazardous to attempt to use other types of gas containers.
- To ensure maximum performance, a gas cylinder of 9kg and minimum of 4.5kg is recommended.
- Check that seals between the appliance and the gas container are in place and in good condition before connecting the gas container.
- Do not use this appliance if it has damaged or worn seals.
- The regulator supplied should be firmly tightened but care must be taken not to over-tighten the connections.
- The regulator supplied is the correct regulator for this item. It is recommended to replace the hose and regulator every 2-3 years.
- When using the cart, ensure barbeque is securely assembled to cart before attempting to connect the gas cylinder. Position and keep gas hose away from cooking fats and grease that may drip, and away from surfaces and parts that may become hot.
- DO NOT USE AN ADAPTOR AT THE CYLINDER CONNECTION.
- Turn off gas at the cylinder supply valve whenever the barbeque is not in use.
- NEVER connect the barbeque to a gas cylinder that is damaged, dented or has been dropped.
- When connected to the barbeque, the gas cylinder should not be exposed to direct sunlight.
- Stored or spare gas cylinders should not be left exposed to direct sunlight.
- For storage and cylinder exchange, disconnect the cylinder only. Do not disconnect the hose from the barbeque.
- Ensure gas cylinder is inspected and tested regularly (the inspection due date can generally be found on the cylinder collar).

3. IF YOU SMELL GAS

DANGER!⚠

DO NOT ATTEMPT TO OPERATE THE BARBEQUE UNTIL THE CAUSE OF THE GAS SMELL HAS BEEN IDENTIFIED AND ELIMINATED.

- If there is a leak from your appliance (smell of gas), immediately attempt to isolate the gas supply by turning off the gas cylinder valve. Remove the appliance to a well-ventilated location away from any ignition sources. Check for leaks using soapy water. Do not try to detect leaks using a flame.
- Extinguish all naked flames.
- Open the hood.
- Ensure that the immediate area is well ventilated to remove any excess gas.
- Check for leaks as described on page 14 under OPERATING INSTRUCTIONS: 'PRECAUTIONARY LEAK TEST'.
- If the gas smell continues, do not use. Disconnect gas supply immediately and call customer service.

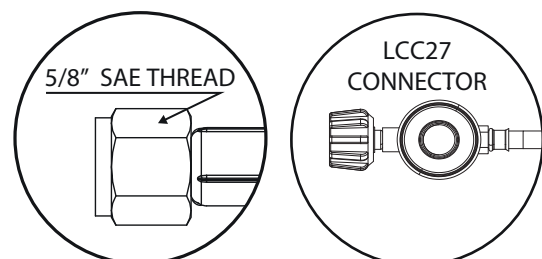

Should there be any concern in making the correct regulator connection please contact the customer service number listed in this user guide.

SETTING UP THE BARBEQUE

This appliance shall only be used in an above ground open air location with natural ventilation.

1. POSITIONING

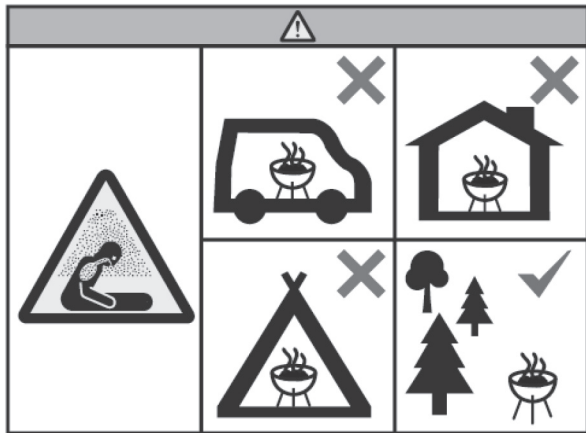

- Please make sure that the barbeque is NOT positioned underneath any combustible material or surface.
- When using barbeque, there MUST be a clearance of at least 250mm from the sides of the barbeque to any combustible materials or surfaces. There must also be a clearance of at least 1500mm above the cooking surfaces to any combustible surface, and 350mm clearance at the back.
- Flammable materials of any description MUST be kept well away from the barbeque.
- The barbeque must be positioned such that the gas cylinder is kept away from direct sunlight.
- The barbeque must be positioned to avoid walkways, gangways and general pedestrian access.
- The nature of a barbeque is such that many of the surfaces are hot to touch, the positioning of the barbeque should take into consideration the possibility of accidental hand or body contact.

ANY ENCLOSURE IN WHICH THE BARBEQUE IS USED SHALL COMPLY WITH ONE OF THE FOLLOWING:

- An enclosure with walls on all sides, but at least one permanent opening at ground level and no overhead cover (EXAMPLE 1).

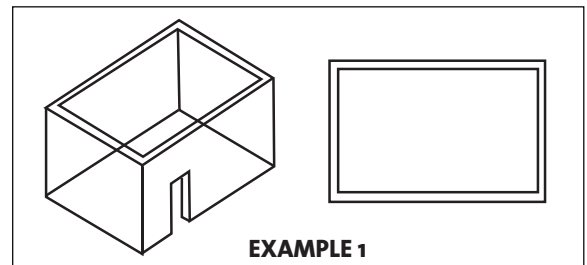

- Within a partial enclosure that includes an overhead cover and two walls (EXAMPLES 2 & 3).

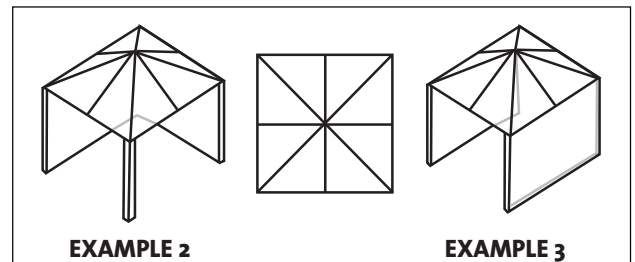

- Within a partial enclosure that includes an overhead cover and more than two walls, the following shall apply:
 - A) at least 25% of the total wall area is completely open; and
 - B) at least 30% of the remaining wall area is open and unrestricted (EXAMPLES 4 & 5).

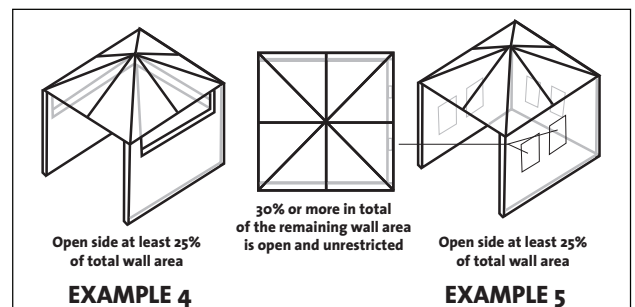

- In the case of balconies, at least 20% of the total of the side, back and front wall areas shall be and remain open and unrestricted.

PARTS AND HARDWARE LIST

Before assembling your barbeque, carefully unpack all parts from packaging. Check that all parts, hardware and tools are included. Check packaging carefully for any missing parts. If any items are missing, please call customer service.

Barbeque Parts List

No	Part Name	Qty
1	Hood Handle	1
2	Hood Handle Left Support	1
3	Hood Handle Right Support	1
4	Hood	1
5	Left Cooking Grill	1
6	Right Cooking Grill	1
7	Top Hood Hinges	2
8	Bottom Hood Hinges	2
9	Heat Plate	1
10	Left Burner	1
11	Right Burner	1
12	Firebox	1
13	Heat Plate Supports	2
14	Hood Latches	2
15	Handle	1
16	Burner Control Knobs	2
17	Oil Cup Support	1
18	Oil Cup	1
19	Tube Caps	4
20	Left Leg	2
21	Right Leg	1
22	Left Leg Caps	2
23	Wheel Caps	2
24	Wheels	2
25	Axle	1
26	Tool Rails	2
27	Stand Lock	1
28	Cushion Pads	2

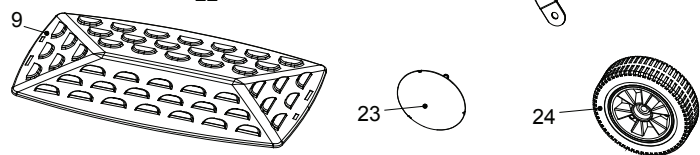
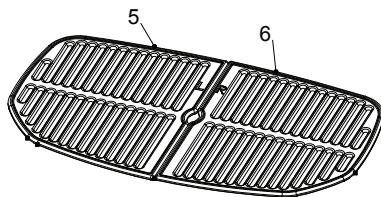
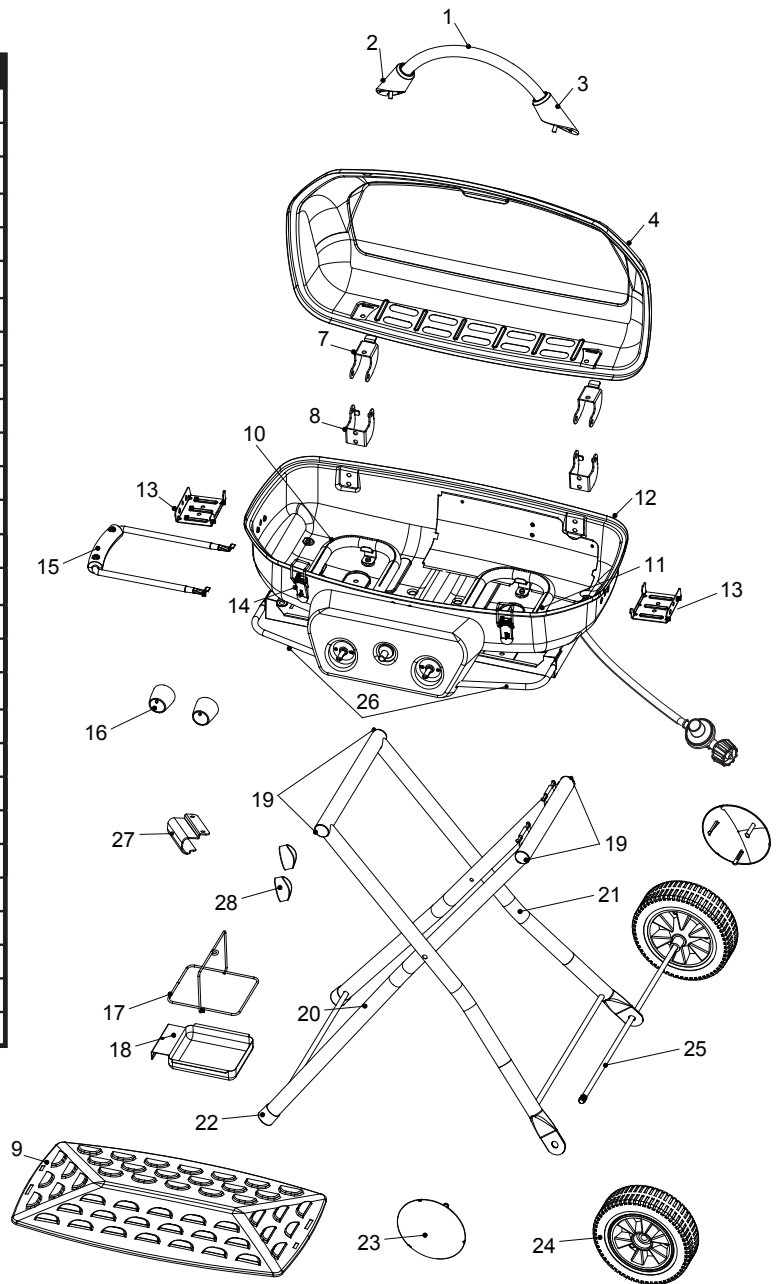

Hardware Parts List

Ref.	Diagram	Hardware Part Name & Descr.	Qty	Ref.	Diagram	Hardware Part Name & Descr.	Qty	Ref.	Diagram	Hardware Part Name & Descr.	Qty
A		Nickel-plated Phillips Truss Head Screw M5X12	7	F		Heat-resistant Washer Ø6.4mm	8	K		Nickel-plated Phillips Truss Head Step Bolt M5X62	2
B		Nickel-plated Phillips Truss Head Screw M6X20	10	G		Nickel-plated Locking Washer Ø6.4mm	12	L		Nickel-plated Hex Nut M5	2
C		Nickel-plated Hex Nut M10	2	H		Spacer Ø18 x Ø11 x 20mm	2	M		Black Phillips Truss Head Screw M4X10	2
D		Nickel-plated Wing Nut M6	10	I		Nickel-plated Phillips Truss Head Bolt M6X47	2	N		Wrench	2
E		Nickel-plated Washer Ø6.2mm	18	J		Nickel-plated Hex Nut M6	2				

You will need a Phillips head screwdriver (not included)

ASSEMBLY TIPS

Allow approximately 20 minutes.

- **Count all parts and hardware before assembling** (see page 5). If any parts are missing, call customer service. Please do not return this item to the store where you purchased it.
- **Choose a firm, smooth surface for assembly** where parts and hardware can't fall or be misplaced. Lay out all parts before assembling, and consider using a container for hardware.
- **Carefully follow these instructions step-by-step.** Parts may look the same but can have slight differences (e.g. left and right legs). Ensuring you have correctly checked the part means you won't have to redo any assembly steps later.
- **If you need assistance during the assembly process**, or don't understand any steps, please call customer service. Have this guide and the model number handy. The model number is printed on the cover page of this guide and on the metal plate affixed to the barbeque.
- **Finger-tighten all hardware connections first**, then tighten with tools provided before moving onto the next step. Don't over-tighten nuts and bolts to prevent stripping the threads.
- **Leak must be performed after assembly** see 'OPERATING INSTRUCTIONS' (See Page 14)
- **LCC27 gas cylinder is required** (LCC27 gas cylinders have an external valve screw).

ASSEMBLY INSTRUCTIONS

STEP 1

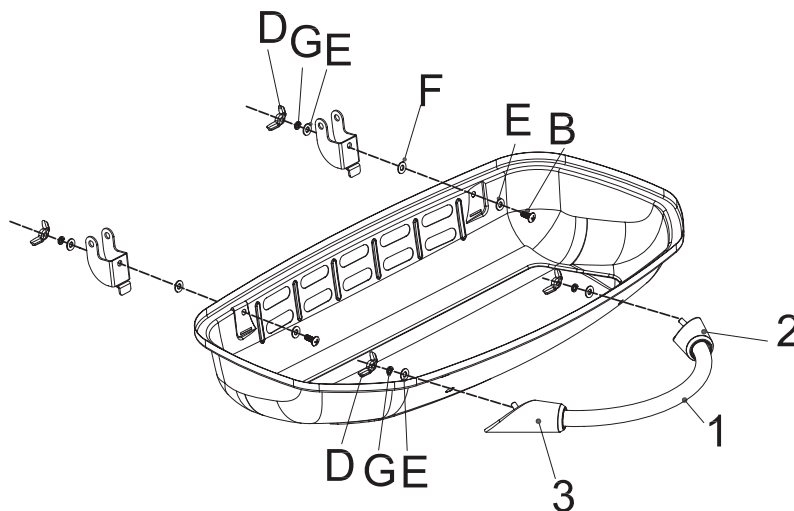

Reference hardware guide at right and assemble in the sequence shown to attach Hood Handle Supports (2 & 3) and Hood Handle (1) to front of Hood (4). Then attach Top Hood Hinges (7) to back of Hood.

Tighten all bolts securely.



B		Nickel-plated Phillips Truss Head Screw M6X20	Qty 2
D		Nickel-plated Wing Nut M6	Qty 4
E		Nickel-plated Washer Ø6.2mm	Qty 6
F		Heat-resistant Washer Ø6.4mm	Qty 2
G		Nickel-plated Locking Washer Ø6.4mm	Qty 4

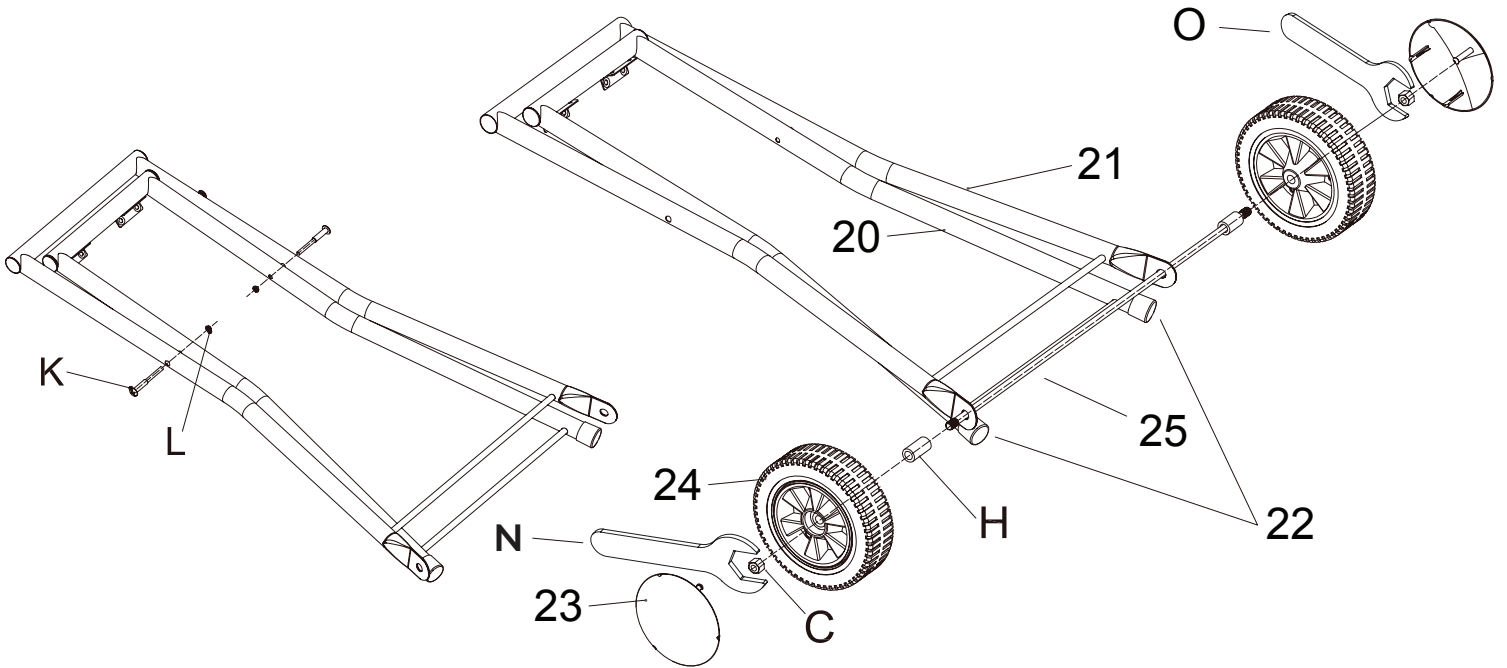

STEP 2

Attach Left Leg (20) to Right Leg (21) with Truss Head Step Bolts (K) and Hex Nuts (L). Ensure Left leg Caps (22) are pressed firmly onto ends of Left Leg. Insert Wheels (24) onto Axle (25) with Spacers (H) and secure with Hex Nuts (C).
TIP: Use both wrenches provided and tighten Hex Nuts (C) at the same time.

Tighten all bolts securely.







K		Nickel-plated Phillips Truss Head Step Bolt M5X62	Qty 2
L		Nickel-plated Hex Nut M5	Qty 2

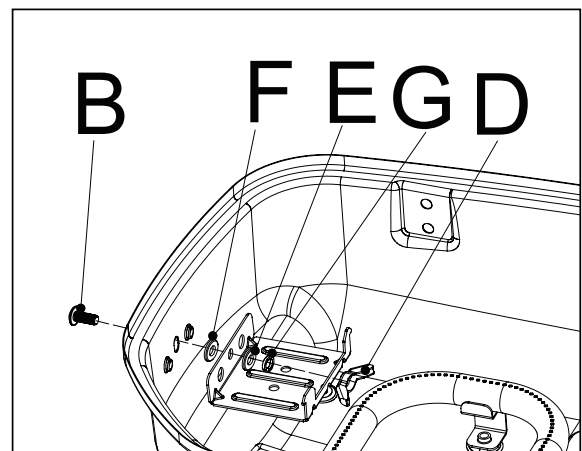
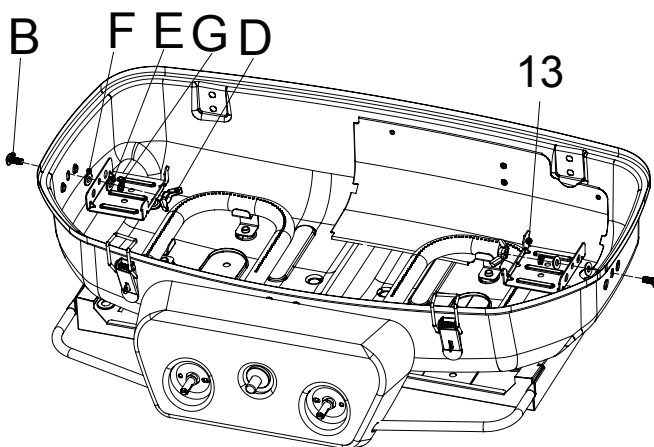

C		Nickel-plated Hex Nut M10	Qty 2
H		Spacer Ø18 x Ø11 x 20mm	Qty 2
N		Wrench	Qty 2

STEP 3

Attach Heat Plate Supports (13) inside on each side of Firebox using hardware as shown. Tighten all bolts securely.



B		Nickel-plated Phillips Truss Head Screw M6X20	Qty 2
D		Nickel-plated Wing Nut M6	Qty 2
E		Nickel-plated Washer Ø6.2mm	Qty 2



F		Heat-resistant Washer Ø6.4mm	Qty 2
G		Nickel-plated Locking Washer Ø6.4mm	Qty 2

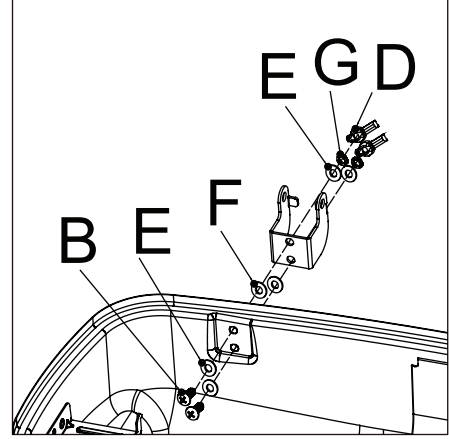
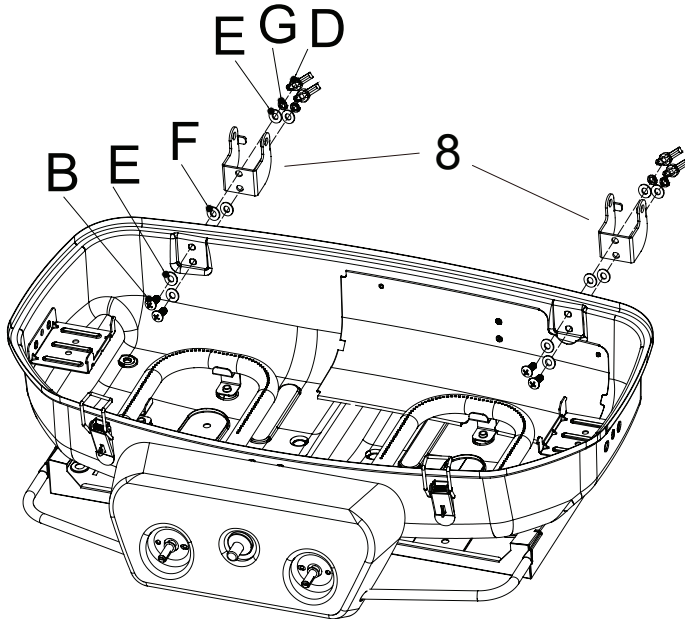

STEP 4

Attach Bottom Hood Hinges (8) to back of Hood using hardware as shown.

Tighten all bolts securely.



B		Nickel-plated Phillips Truss Head Screw M6X20	Qty 4
D		Nickel-plated Wing Nut M6	Qty 4
E		Nickel-plated Washer Ø6.2mm	Qty 8



F		Heat-resistant Washer Ø6.4mm	Qty 4
G		Nickel-plated Locking Washer Ø6.4mm	Qty 4

STEP 5

Attach Handle (15) and Stand Lock (27) to bottom of Firebox using hardware as shown.

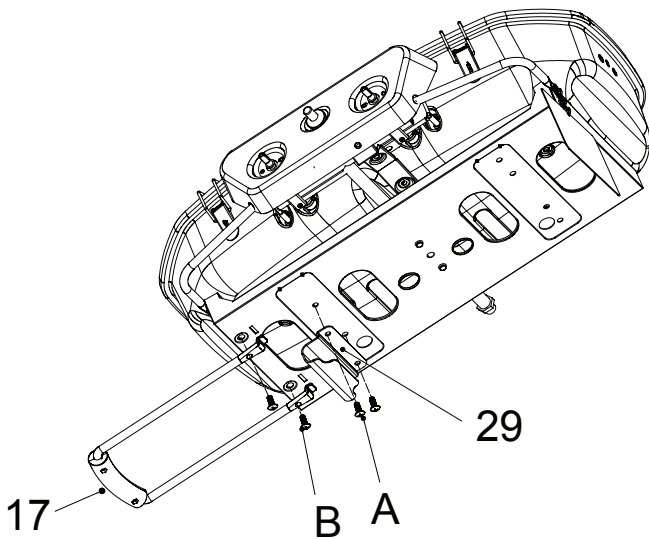
Tighten all screws securely.





A		Nickel-plated Phillips Truss Head Screw M5X12	Qty 2
B		Nickel-plated Phillips Truss Head Screw M6X20	Qty 2

STEP 6

Attach Cushion Pads (28) to Left Leg, then attach Legs to bottom of Firebox using hardware as shown.

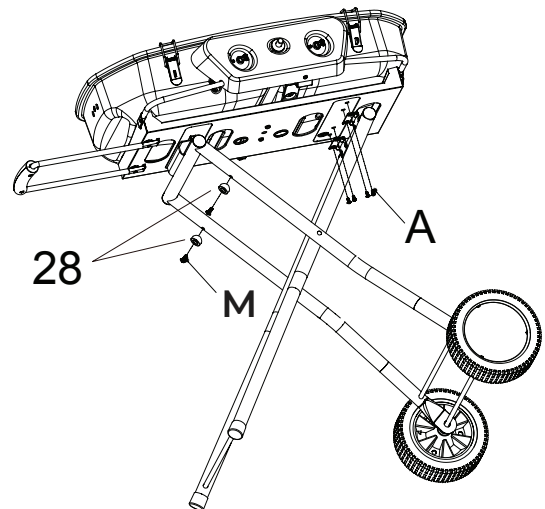
Tighten all screws securely.



A		Nickel-plated Phillips Truss Head Screw M5X12	Qty 4
M		Black Phillips Truss Head Screw M4X10	Qty 2

STEP 7

Stand the barbeque upright in the locked position. Lift it up, unfold the legs and hook the Left Leg under the Stand Lock.

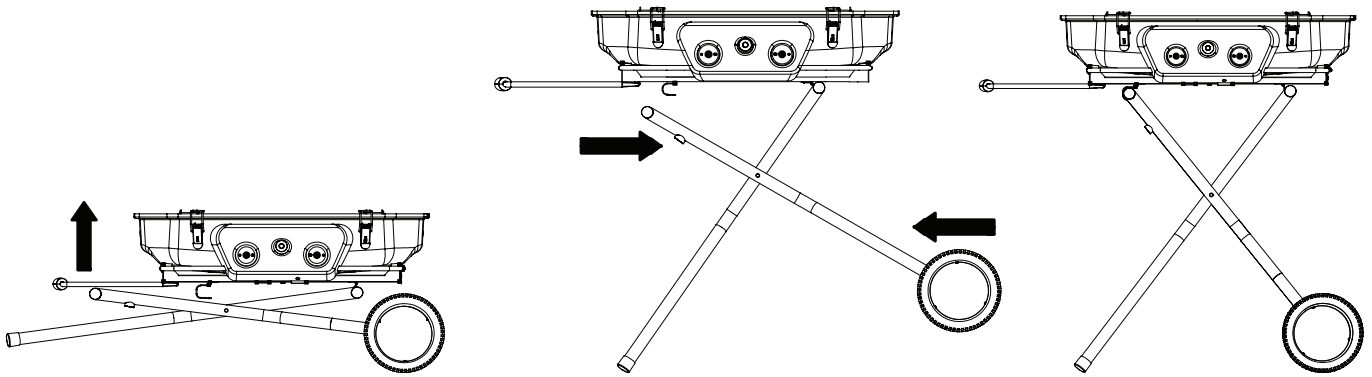

STEP 8

Attach Burner Control Knobs (16) to front of barbeque by pressing each knob onto its spindle.

Ensure each knobs are pushed all the way down on the spindles

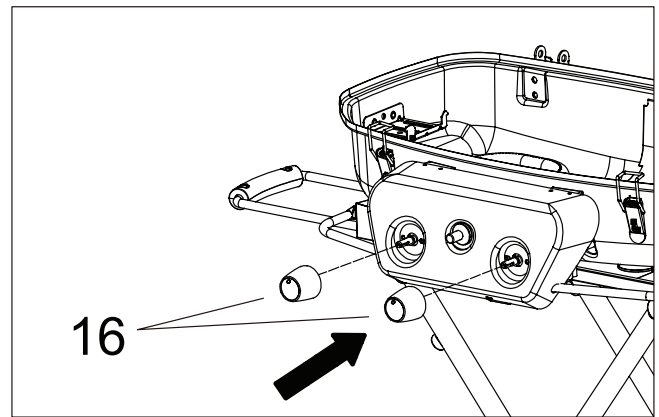

STEP 9

Place Heat Plate (9) on Heat Plate Supports. Ensure prongs on Heat Plate Supports protrude through holes in Heat Plate (as shown below):

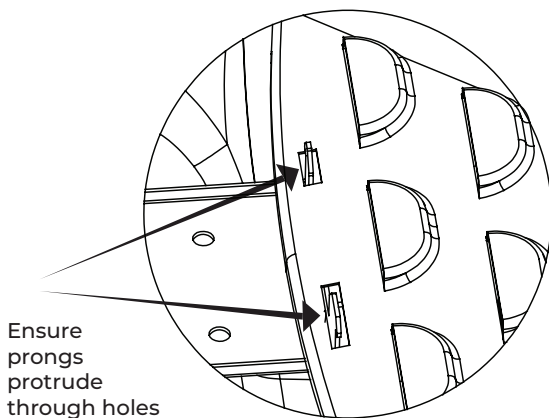

When Heat Plate is installed, place Left and Right Cooking Grills (5 & 6) on top lip of Firebox. Ensure Cooking Grills sit flush with top edge of Firebox.

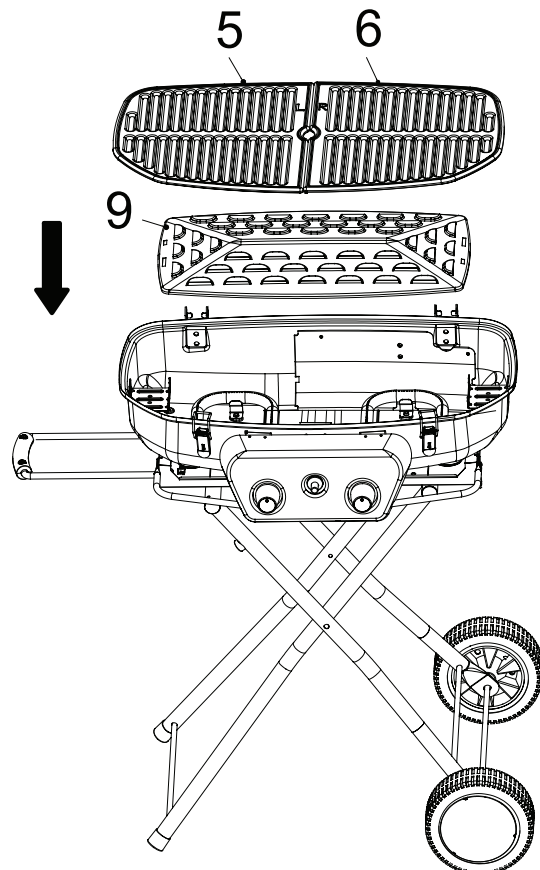



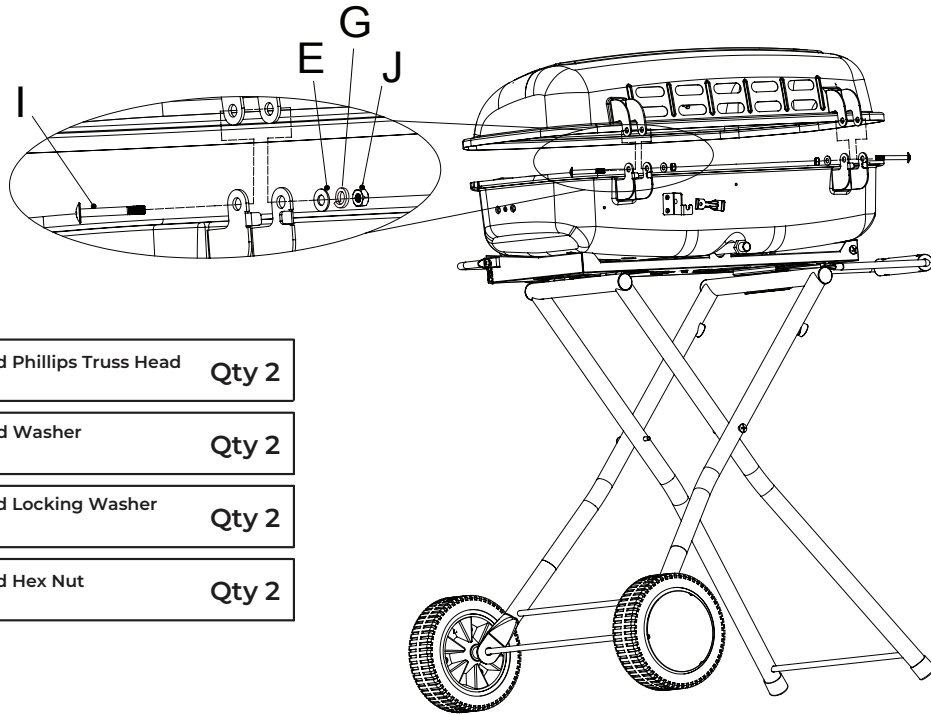

STEP 10

Place Hood on Firebox and make sure that Top and Bottom Hood Hinge holes align, then connect hinges by inserting Bolt (I) through hinge holes and secure with hardware as shown.

Tighten all bolts securely.



I		Nickel-plated Phillips Truss Head Bolt M6X47	Qty 2
E		Nickel-plated Washer Ø6.2mm	Qty 2
G		Nickel-plated Locking Washer Ø6.4mm	Qty 2
J		Nickel-plated Hex Nut M6	Qty 2

STEP 11

Attach Oil Cup Support (17) to underside of Firebox with hardware as shown, then place Oil Cup (18) in support.

A		Nickel-plated Phillips Truss Head Screw M5X12	Qty 1
---	---	---	-------

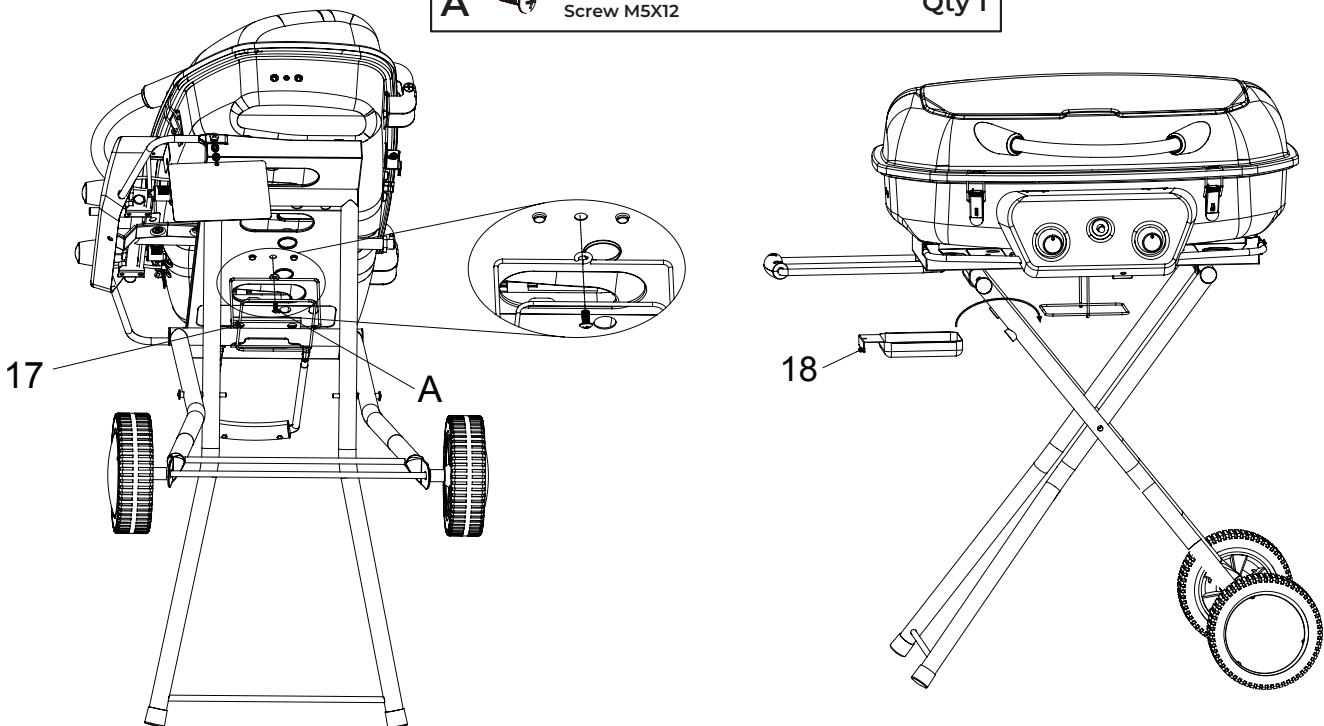

MAINTENANCE OF FIXINGS

Over time and with regular use the fixing screws and nuts may start to become loose. A regular check of all fixings is recommended.

FOLDING, UNFOLDING AND TRANSPORTING THE BARBEQUE

WARNING! ⚠ HOOD LATCHES MUST BE CLOSED TO LOCK THE HOOD WHILE FOLDING OR TRANSPORTING THE BARBEQUE. HOOD MUST BE OPEN WHEN LIGHTING BARBEQUE.

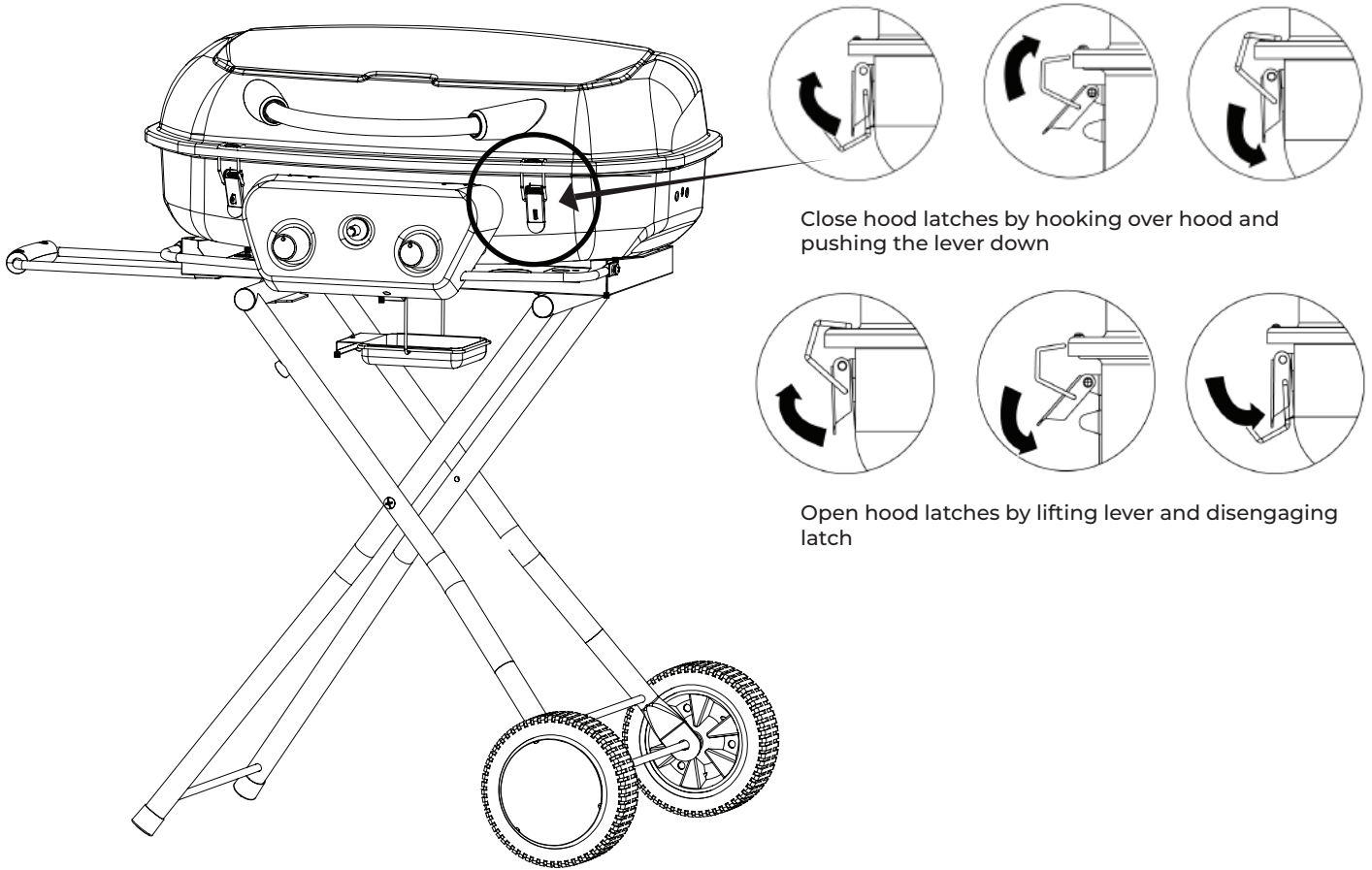

TO FOLD BARBEQUE

Close hood latches, then unhook top of left leg from stand lock. Engage lock on left leg with body of barbecue to prevent legs unfolding when lifting. Barbeque is now ready to transport. Always grip handle firmly when wheeling barbecue.

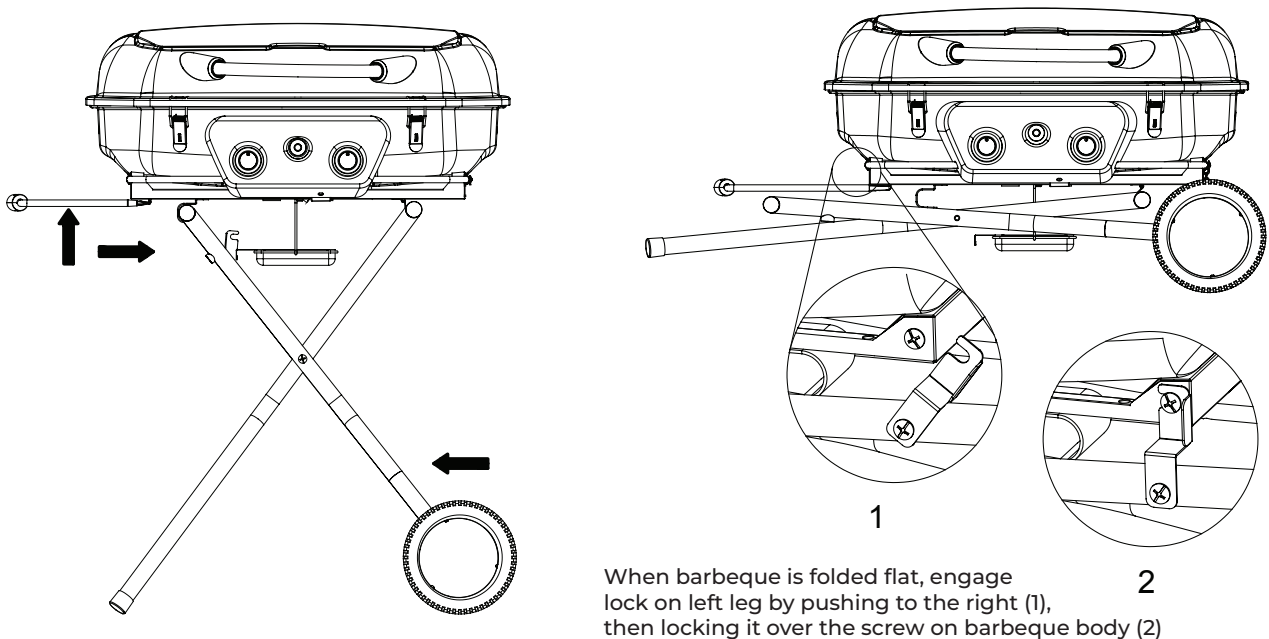

TO UNFOLD BARBEQUE

Make sure barbeque is on a firm, level surface. Disengage lock on rear of barbeque. Lift barbeque up, unfold the legs and hook the left leg under the stand lock. Release the hood latches. Barbeque is now ready for use.

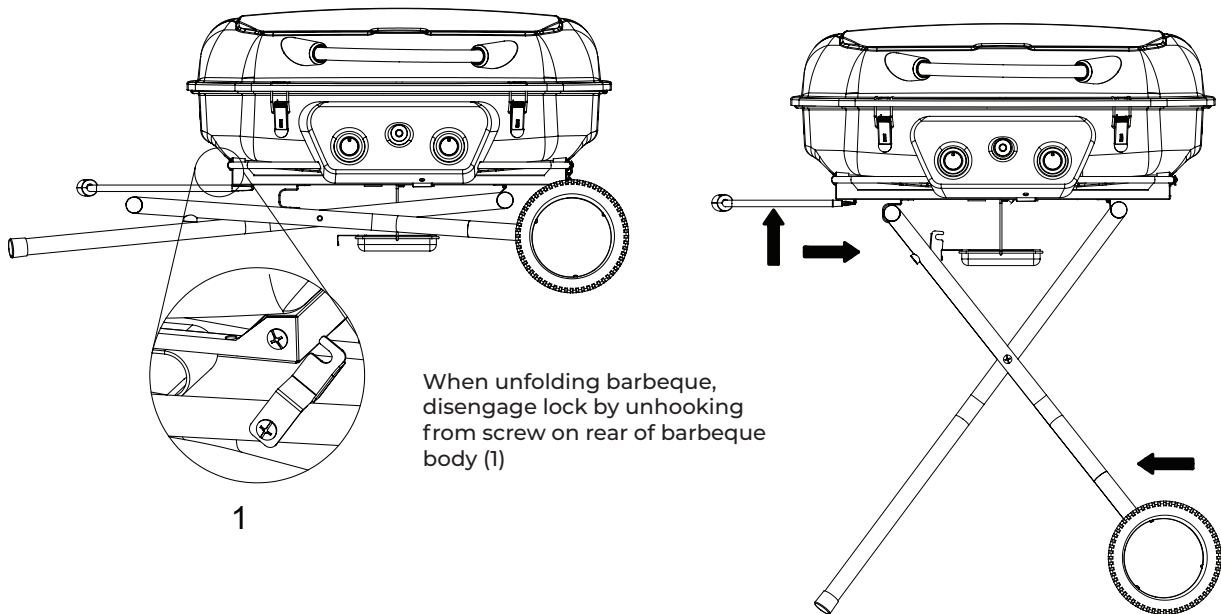

LOCATING THE BARBEQUE AND FIRST TIME USE

Back and sides of the barbeque must be located a minimum of 53cm away from walls or other structures when barbeque is in use.

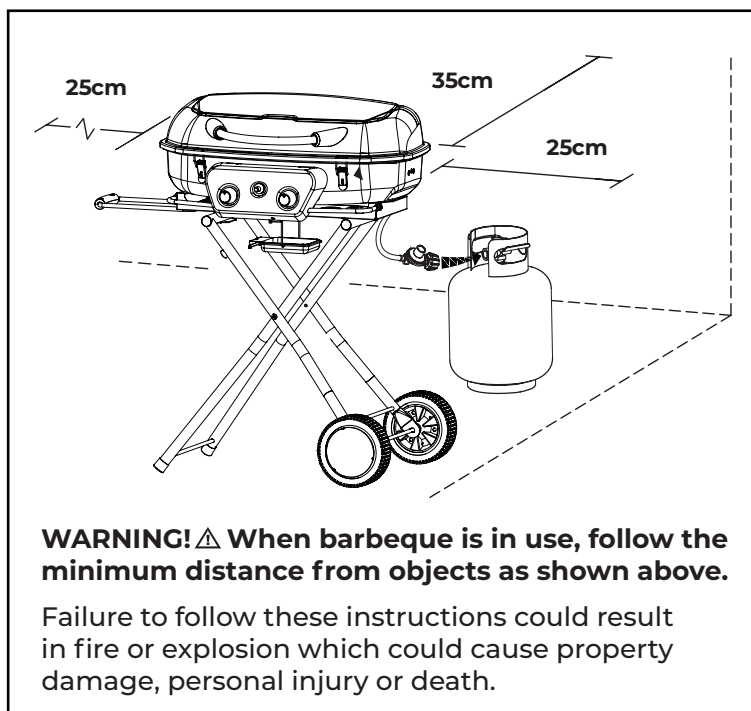

This barbeque has a porcelain-enameled cooking surface. This does not require any seasoning and will provide years of service.

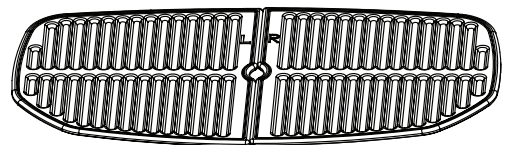

Before using for the first time, wash the grills in hot soapy water and dry thoroughly.

USING, CONNECTING & DISCONNECTING PROPANE CYLINDER

A. Place gas cylinder on a firm level surface

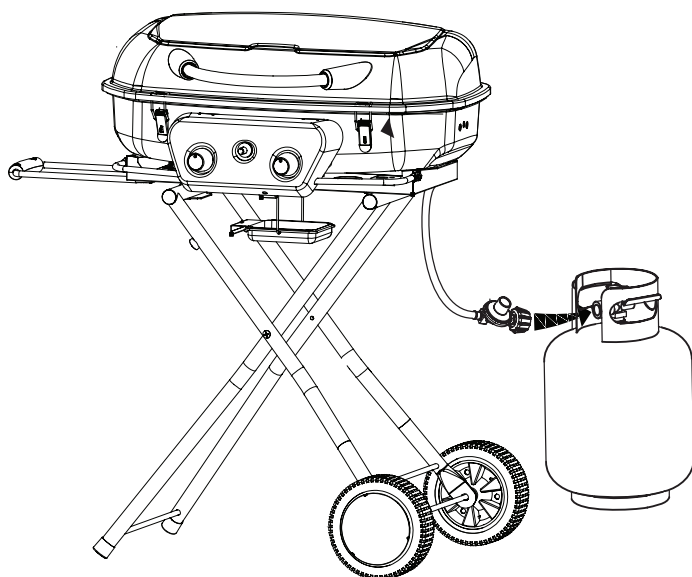

To operate, you will need a standard barbeque propane cylinder with external valve threads.
(LCC27 cylinder connection)

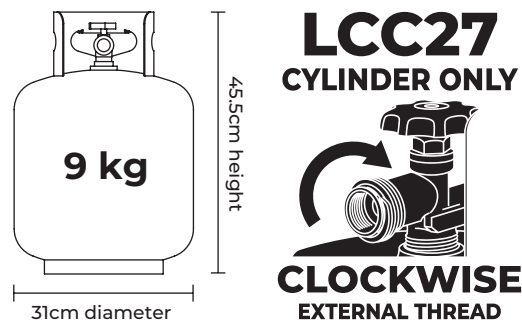

CAUTION! ⚠

Never move barbeque with propane cylinder in place. Propane cylinder must be properly disconnected and removed before moving this barbeque.

B. To connect cylinder, screw end of hose tightly onto cylinder in a clockwise direction. Attach restraint chain to cylinder as shown (see right).

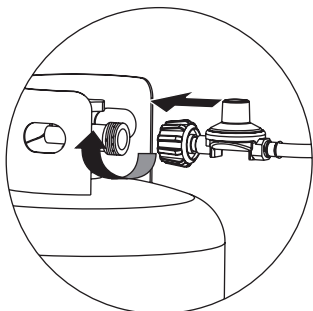

C. To disconnect cylinder, turn end of hose in an anti-clockwise direction. Unhook restraint chain.

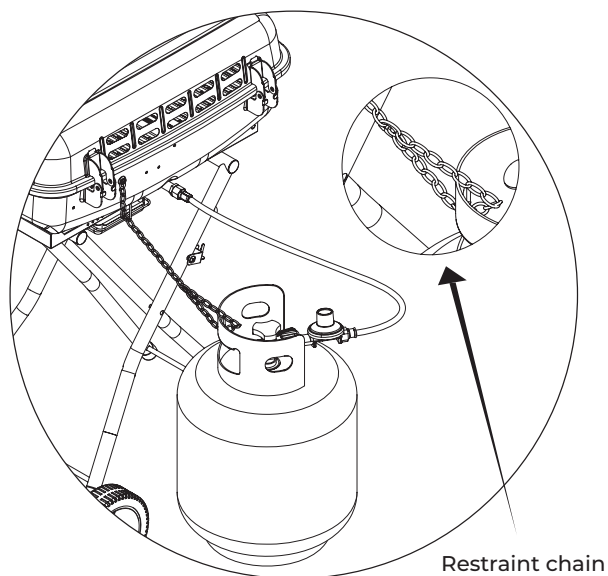
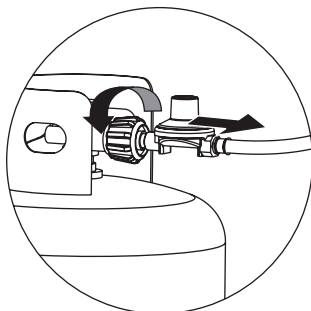

Connecting Propane Cylinder

1. Before connecting the cylinder, remove any debris in or around the head of the gas cylinder, regulator valve, burner heads and burner ports. Use a brush to clean burner ports if necessary.
2. Connect regulator/hose assembly to cylinder by turning knob clockwise until hose is fully tightened.

Disconnecting Propane Cylinder

1. Before disconnecting cylinder, make sure the propane cylinder valve is closed by turning the top valve clockwise until it is fully tightened.
2. Disconnect regulator/hose assembly from propane cylinder by turning knob anti-clockwise until it disconnects from cylinder.
3. Place the protective cap cover on the propane cylinder and store the outdoors in a well ventilated area away from direct sunlight.

OPERATING INSTRUCTIONS

BURNER CONNECTIONS

1. Make sure the regulator hose and valve connections are securely fastened to the burner and the cylinder.
2. Visually check the connection between the burner/venturi tube and orifice (Fig. 1).
3. Make sure the burner/venturi tube fits over the orifice.
4. Please refer to diagram for proper installation.
If the burner/venturi tube does not rest flush to the orifice, as shown, please contact customer service for assistance.

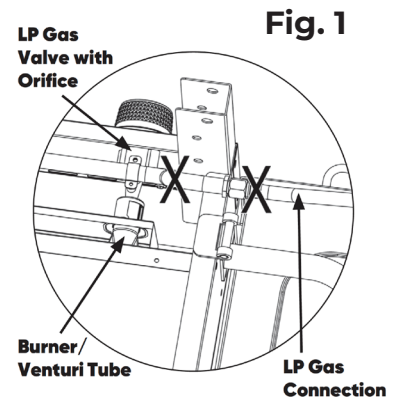

WARNING! Δ Failure to inspect this connection or follow these instructions could cause a fire or an explosion which can cause death, serious bodily injury or damage to property.

PRECAUTIONARY LEAK TEST

1. Make about 60mL of leak detection solution by mixing one part dishwashing liquid with three parts water.
2. Make sure control knobs are in the 'OFF' position.
3. Connect propane cylinder (see previous page).
4. Turn propane cylinder valve to 'OPEN'.
5. Use a spoon or spray bottle to apply the solution you made to all locations marked with an 'X' shown in Figs. 1 and 2.
6. If any bubbles appear, turn propane cylinder valve to 'CLOSED', reconnect any connections you made, and re-test.
7. If you continue to see bubbles after several attempts, turn propane cylinder valve to 'CLOSED' and disconnect propane cylinder (see previous page). Contact customer service for assistance.

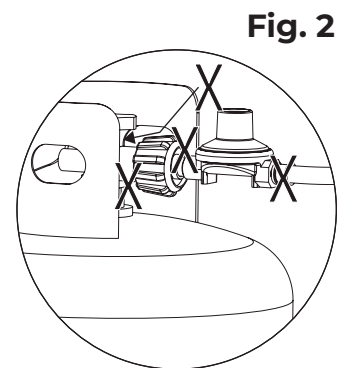

LIGHTING THE BARBEQUE (CAUTION! Δ HOOD MUST BE OPEN WHEN LIGHTING)

1. Make sure all labels, packaging and protective films have been removed from the barbeque and that the barbeque grills have been washed thoroughly.
2. Check for obstructions of airflow to the burners.
Spiders, webs, insects and debris can clog the burner/venturi tube. A clogged burner tube can lead to a fire.
3. Ensure control knobs are in the 'OFF' position.
4. Connect propane cylinder (see page 13).
5. Turn propane cylinder valve to 'OPEN'.
6. Turn control knob to 'HIGH' and press ignition button.
The burner should light. If it does not, repeat this step up to three times.
If burner still does not light, turn control knob to 'OFF', wait 5 minutes and repeat lighting procedure.
7. TO LIGHT MANUALLY
If igniter does not light burner, use a long lit match to light each burner (Matches are not included). Remove cooking grills and heat plate first (Fig. 3).
Position lit match above each burner to light.

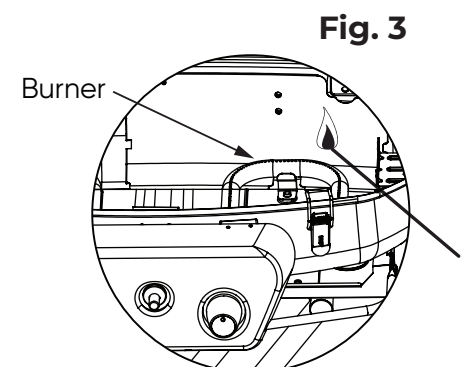

To light manually, remove both cooking grills and heat plate, then position long lit match above burners to light

OPERATING INSTRUCTIONS (cont'd)

- After lighting, observe the burner flame. Make sure all burner ports are lit and flame height and appearance matches correct flame appearance below.

NOTE: each burner lights independently. Follow steps 6 - 8 to light the other burner.

CAUTION!△ Before lighting barbeque make sure outdoor cooking appliance areas are clear and free from combustible materials, gasoline and other flammable vapors and liquids.

CAUTION!△ Do NOT obstruct the flow of combustion and ventilation air.

CAUTION!△ Before each use, check burner/venturi tubes for insects and nests. Clean if necessary. A clogged tube can lead to a fire.

CAUTION!△ Do NOT use non-stick cooking sprays on this barbeque. The high water content can cause them to burn and damage the grill surface.

CAUTION!△ Do NOT use corn oil when cooking on this barbeque as it contains sugar, which can caramelize and burn onto the surface of the grill.

CAUTION!△ If burner flame goes out during operation, immediately turn the control knobs to the 'OFF' position, turn the propane cylinder valve to 'CLOSED' and open lid to let the gas clear for 5 minutes before relighting.

BURNER FLAME APPEARANCE GUIDE

- Each time barbeque is started you should check the flame appearance. When each burner is lit and set to 'HIGH', you should see soft blue flames (about 2 - 3cm long) with yellow tips.
- Flames should burn evenly and not erratically. If flames appear all blue or all yellow, this indicates the burners need cleaning or replacing.

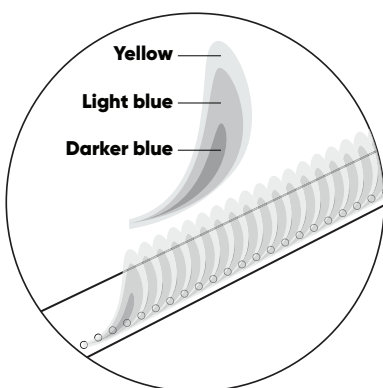

A. Correct - smooth, soft flame with darker blue bottom and yellow tips

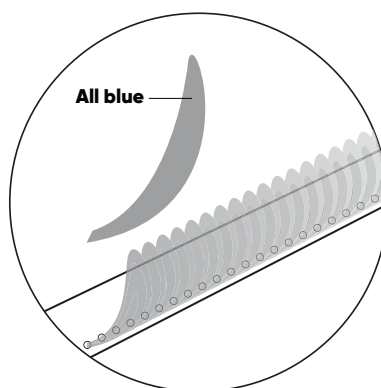

B. Incorrect - all blue flame and noisy operation (e.g. popping) indicates that burners need cleaning or replacing

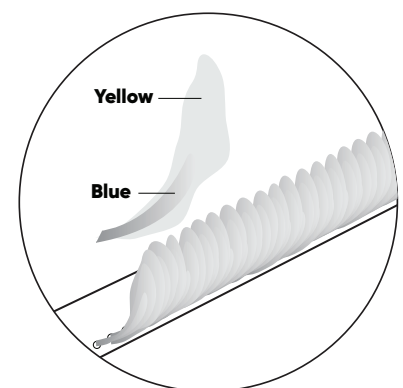

C. Incorrect - uneven flames that are mostly yellow, red or orange means burners need cleaning or replacing, or gas pressure is too low due to a leak or faulty regulator

OPERATING INSTRUCTIONS (cont'd)

BURNER CONTROL SETTINGS FOR DIRECT AND INDIRECT GRILLING

Designed for high heat output when the hood is closed, this barbeque is ideal for quickly searing juicy steaks and burgers. Use the burners as shown below for delicious grilling results - every time by making the most of indirect and direct cooking zones.

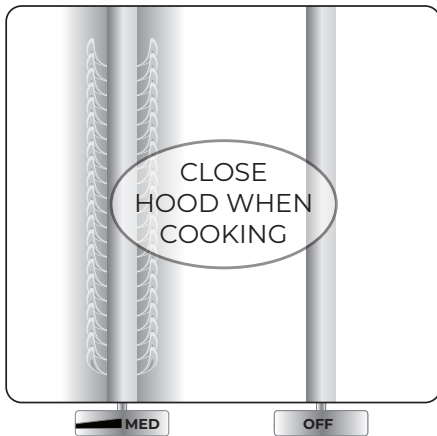

A. INDIRECT ZONE COOKING

IDEAL FOR ROASTING (2 - 3 HOURS)

- Prime rib
- Whole chicken
- Baking bread or cakes

Light the left or right burner and set to MEDIUM heat. Place food above the unlit burner. Close hood. Your barbeque will cook food like an oven does. Use a barbeque thermometer to ensure desired temperature is maintained and adjust burner setting up or down as needed.

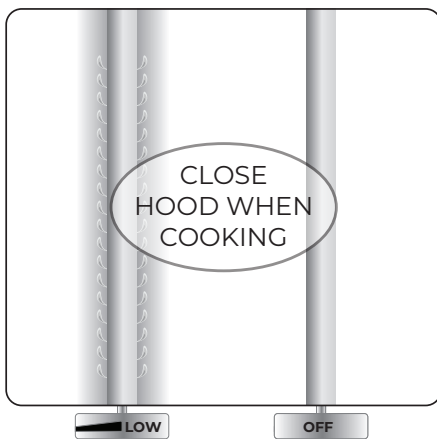

B. INDIRECT SURROUND COOKING

IDEAL FOR SLOW COOKING (4 - 10 HOURS)

- Brisket
- Pulled pork
- Smoking foods

Light the left or right burner. Set each to MED-LOW heat. Place food above the unlit burner. Close hood. Your barbeque will cook food like a smoker - low and slow. Use a barbeque thermometer to ensure desired temperature is maintained and adjust burner setting up or down as needed.

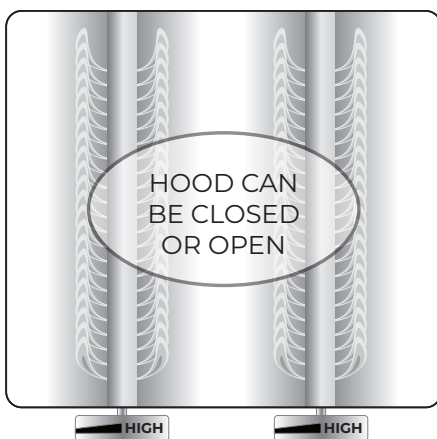

C. 100% DIRECT COOKING

COOKS FOOD IN MINUTES

- Steaks
- Burgers (meat and plant-based)
- Searing fish and vegetables

Light both burners and set to HIGH heat. Use a barbeque thermometer to ensure desired temperature is maintained and adjust burner settings up or down as needed. Turn food once after 2-6 minutes to complete cooking.

OPERATING INSTRUCTIONS (cont'd)

CONTROLLING FLARE-UPS

CAUTION!⚠

If a grease fire develops, turn control knobs to the 'OFF' position and propane cylinder valve to 'CLOSED'. Do NOT use water on a grease fire. This can cause the grease to splatter and could result in serious burns, bodily harm or other damage.

Do NOT leave barbeque unattended while preheating or burning off food residue on or 'HIGH'. If barbeque has not been cleaned, a grease fire can occur.

WARNING!⚠ When cooking, fire extinguishing materials should be readily accessible. In the event of an oil/grease fire, use type BC dry chemical fire extinguisher or smother with dirt, sand or baking soda. Do NOT attempt to extinguish with water.

Flare-ups are a part of cooking meats on a barbeque and add to the unique flavor of grilling. **However, excessive flare-ups can overcook your food and can be dangerous.**

Important: Excessive flare-ups result from the build-up of grease in the oil cup. If a grease fire occurs, turn the control knob(s) to 'OFF' until the grease burns out. If excessive flare-ups occur, DO NOT pour water onto the flames.

To minimise flare-ups

1. Trim excess fat from meats prior to cooking.
2. Cook high fat content foods on 'LOW' setting or indirectly. Indirect cooking is when you use the burners on one side of the grill only and cook food on the opposite side of the grill (or on the warming rack). This means the food you are cooking will cook more slowly as it is not cooking over direct heat.
3. Ensure that your barbeque is on a hard, level non-combustible surface and that grease is allowed to drain into the oil cup.

BARBEQUE CLEANING AND CARE

CAUTION!⚠

1. All cleaning and maintenance should be done when the barbeque is completely cool and the gas supply has been disconnected (see page 13).
2. Do NOT clean any part of the barbeque in a self-cleaning (pyrolytic) oven. The extreme heat generated during pyrolysis will damage the finish.
3. Take care not to enlarge valve orifices or burner ports when cleaning the valves or burners.

IMPORTANT

1. This barbeque should be thoroughly cleaned and inspected on a regular basis.
2. Abrasive cleaners will damage this product.
3. Never use oven cleaner to clean any part of the barbeque.

BEFORE EACH USE

1. Keep the barbeque area clean and free from any combustible materials, gasoline, and other flammable vapours and liquids.
2. Do NOT obstruct the flow or the combustion of propane, or the barbeque vents.
3. Keep the propane cylinder free and clear of debris.
4. Visually check the burner flames to make sure your barbeque is working properly (page 15).
5. Check for obstructions of airflow to the burners. Spiders, insects and webs can clog the burner/venturi tube. A clogged burner tube can lead to a fire.

BARBEQUE CLEANING AND CARE

1. Wipe surfaces clean with a solution of mild dishwashing detergent or baking soda mixed with water.
2. For stubborn surfaces, use a citrus-based degreaser and a nylon scrubbing brush.
3. Rinse clean with water and allow to air dry.

BURNER CLEANING AND CARE (Barbeque must be completely cool)

1. Turn gas cylinder valve to 'CLOSED'.
2. Turn all control knobs clockwise to the 'OFF' position.
3. Disconnect gas cylinder (page 13).
4. Carefully remove grills and heat plate and place where they will not obstruct access to the burners. Then remove the fasteners which secure the burners to the firebox.
5. Grasp the rear part of the burner and lift it up and away from the gas valve orifice.
6. Disconnect wire from spark electrode (if applicable).
7. Clean the venturi tube end of each burner and the outlet holes with small bottle brush or compressed air.

BARBEQUE CLEANING AND CARE (cont'd)

8. Remove all residue and dirt from burner surfaces.
9. Clean any clogged ports with a stiff wire brush (or an opened paper clip).
10. Inspect burners for any damage (cracks or holes). If damage is found, replace with new burner(s). Call customer service to order replacement burners.
11. Re-install burner(s) by reconnecting spark electrode and inserting venturi tube end over gas valve orifice. Before securing with fasteners, check to ensure that gas valve orifice is correctly positioned inside each burner. Also, check connection of each spark electrode (if applicable).
12. Replace heat plate and grills.
13. Reconnect gas cylinder and perform PRECAUTIONARY LEAK TEST (see page 14).

AFTER EACH USE

1. After cooking, turn burners onto 'HIGH' for 5 minutes to burn off food residue, then turn 'OFF' and allow to cool.
2. While still warm, scrape off any remaining food residue with a scraper or barbeque stone.
3. Remove cooking surfaces and wipe inside of hood and firebox with paper towel until clean.
4. Light barbeque, close hood and allow burners to remain on high for 15 minutes, then turn burners 'OFF'.
5. Repeat steps 2 - 4 if necessary and wipe cooking surfaces and inside of hood to remove any residue.

STORING THE BARBEQUE

1. Turn propane cylinder tank valve to 'CLOSED' and disconnect gas cylinder.
2. Turn all control knobs clockwise to the 'OFF' position.
3. Clean all surfaces.
4. Lightly coat the burner(s) with cooking oil to prevent rusting
5. Place the protective cap cover on the propane cylinder and store cylinder outdoors in a well-ventilated area out of direct sunlight.
6. If storing indoors, cover the barbeque and store in a cool dry place.
7. If storing outdoors, cover with a barbeque cover for protection from the weather.



TECHNICAL INFORMATION

TECHNICAL SPECIFICATIONS

Model	BG2102D2
Gas Type	Propane
Burner Injector Size	0.94mm
Burner Gas Consumption	11 MJ/hr
Burner Gas Pressure	2.75 Kpa
Total Gas Consumption	22 MJ/hr
Approval Number	GSCS 20243

CUSTOMER SERVICE, PARTS AND PRODUCT REGISTRATION INFORMATION

PLEASE DO NOT RETURN THIS BARBEQUE TO THE STORE WHERE YOU PURCHASED IT. Call our Customer Service Centre number listed below.

IF AT ANY TIME YOU ARE IN ANY DOUBT ABOUT THE CORRECT COMPONENTS TO BE USED WITH THIS BARBEQUE, OR ANY OTHER ASPECT OF THE Barbeque'S USE AND FUNCTION, PLEASE CONTACT OUR CUSTOMER SUPPORT.

FOR REPLACEMENT PARTS, CONTACT OUR CUSTOMER SERVICE CENTRE.

BRAND-MAN GRILLS CUSTOMER SERVICE CENTRE:

Hours - 9AM to 5:00PM AEST M-F (excluding holiday)

**PHONE: 1300 667 146 (AUS)
0800 585 300 (NZ)**

**EMAIL:
help@solutionservices.net.au**

TROUBLESHOOTING GUIDE

Problem	Possible Cause	Prevention/Fix
Burner will not light using igniter	Propane cylinder valve is closed	Make sure regulator is securely attached to the propane cylinder per 'Connecting propane cylinder,' then turn gas cylinder valve to 'OPEN'
	Propane cylinder is low or empty	Exchange or refill propane cylinder
	Propane cylinder is leaking	1. Turn propane cylinder valve to 'CLOSED' 2. Wait 5 minutes for gas to clear 3. Check for leaks - see 'Precautionary Leak Test' section (page 14)
	Burner wire(s) or electrode(s) covered with cooking residue	Clean wire and/or electrode with rubbing alcohol
	Electrode and burners are wet	Wipe dry with cloth
	Electrode cracked/broken - sparks at crack	Replacement part(s) may be needed - contact Customer Care
	Ignition wires loose or disconnected	Reconnect wire or replacement part(s) may be needed - contact Customer Care
	Wire is shorting (sparking) between igniter and electrode Malfunctioning igniter	Replacement part(s) may be needed - contact Customer Care Replacement part(s) may be needed - contact Customer Care
Burner will not light with match	No gas flow	Check if propane cylinder is empty A. If empty, exchange or refill propane cylinder B. If propane cylinder is empty, refer to 'Sudden drop in gas flow or reduced flame height' (see below)
	Propane cylinder is low or empty	Exchange, refill or replace propane cylinder
	Propane cylinder/regulator safety connection	1. Turn propane cylinder valve to 'CLOSED' 2. Wait 5 minutes for gas to clear 3. Follow 'Checking for Leaks' section
	Coupling nut and regulator not fully connected	Turn the coupling nut about one-half to three-quarters additional turn until solid stop Tighten by hand only - do NOT use tools
	Obstruction of gas flow	1. Clear burner/venturi tube 2. Check for bent or kinked hose
	Disengagement of burner to valve	Re-engage burner and valve - see 'Burner cleaning and care' - page 18
	Spider webs or insect in venturi tube	Clean burner/venturi tube - see 'Burner cleaning and care' - page 18
	Burner ports clogged or blocked	Clean burner ports - see 'Burner cleaning and care' - page 18
Sudden drop in gas flow or reduced flame height	Out of gas	Exchange or refill propane cylinder
	Overfilling prevention device may have been activated	1. Turn control knob to 'OFF' 2. Wait 30 seconds and light barbeque 3. If flames are still too low, reset the overfilling prevention device: a. Turn control knob(s) 'OFF' b. Turn propane cylinder valve to 'CLOSED' c. Disconnect regulator d. Turn control knobs to 🔥 and 🔥 (HIGH) e. Wait 1 minute f. Turn control knobs to 'OFF' g. Reconnect regulator and leak check connections, being careful not to fully open valve h. Light barbeque per 'Lighting' section
Sudden drop in gas flow or reduced flame height	Burner ports are clogged or blocked	Clean burner ports - see 'Burner cleaning and care' - page 18
Flame is yellow or orange	New burner may have residual manufacturing oils	Burn barbeque for 15 minutes on 🔥 and 🔥 (HIGH) with the hood closed
	Spider webs or insect nest in venturi tubes	Clean venturi tubes - see 'Burner cleaning and care' - page 18
	Food residue, grease, etc. on burners	Clean burner tubes - see 'Burner cleaning and care' - page 18
	Poor alignment of valve to burner/venturi tube	Ensure burner/venturi tube is properly engaged with valve - see page 18
Flame goes out	High or gusting winds	Do not use barbeque in high wind
	Gas cylinder is low	Exchange or refill propane cylinder
	Overfilling prevention device may have been activated	Refer to 'Sudden drop in gas flow or reduced flame height' - above
Flare-up	Grease buildup	Remove and clean barbeque parts per 'Cleaning and Care' Section
	Excess fat in meat	Trim fat from meat before cooking
	Excessive cooking temperature	Adjust to lower cooking temperature
Persistent grease fire	Excessive cooking temperature	1. Turn control knobs to 'OFF' 2. Turn propane cylinder valve to 'CLOSED' 3. Leave lid in closed position and let fire burn out 4. After barbeque cools, remove and clean all parts per 'Cleaning and Care' section
Flashback fire in burner tube(s)	Burners and/or burners/venturi tubes are blocked	Adjust to lower cooking temperature
Barbeque Surface	Barbeque has started to rust	With use the barbeque surface may show signs of rust. This is normal.
	Barbeque cooking surface is chipped or has other damage	The cooking surface may develop slight chips over time. This is normal. If bent or badly damaged, replacement grills can be ordered by contacting customer service.

For assistance, please call customer service - Tel. 1300 667 146 (AUS) or 0800 585 300 (NZ), or email: help@solutionservices.net.au



WARRANTY INFORMATION

12 MONTH LIMITED WARRANTY

Thank you for your purchase.

Your new product is warranted to be free from defects in material and workmanship for the period stated above, from the date of purchase, provided that the product is used in accordance with accompanying recommendations or instructions where provided. This warranty is in addition to your rights under the Australian Consumer Law.

You will be provided with your choice of refund, repair, or exchange (where possible) for this product if it becomes defective within the warranty period. This warranty will no longer apply where defects is a result of alteration, accident, misuse, abuse or neglect.

Please retain your receipt as proof of purchase and contact the Customer Service Centre on 1300 667 146 or 0800 585 300 (New Zealand) or alternatively via email at help@solutionservices.net.au for any difficulties returning this product. Warranty claims and claims for expense incurred in returning this product can be addressed to our Customer Service Centre at PO Box 6320, Point Cook, Victoria 3030, Australia.

Our goods come with guarantees that cannot be excluded under the Australian Consumer Law. You are entitled to a replacement or a refund for a major failure and compensation for any other reasonable foreseeable loss of damage. You are also entitled to have the goods repaired or replaced if the goods fail to be of acceptable quality and the failure does not amount to a major failure.

This warranty covers domestic use only and does not apply to commercial applications.

For New Zealand customers, this is in addition to statutory rights observed under New Zealand legislation.

DISCLAIMERS

The manufacturer reserves the right to change and amend the specifications without prior notice.

Failure to follow the instructions in this manual will void any warranties offered on the product.

Modifications to the barbeque in any fashion will null and void the warranty of the item.

Any replacement components should be supplied from the customer service centre.

The correct regulator and valves must be used with this barbeque. The use of incorrect or faulty valves and regulators can create a dangerous condition. The use of inappropriate regulators and valves will void the warranty.

This warranty does not cover claims arising from fat fires.

This warranty does not cover rust as we cannot control the environment in which the barbeque is stored.

This warranty is given by

Icon Services Pty Ltd

ABN 87 602 265 547

109/22-30 Wallace Ave, Point Cook, VIC 3030, Australia